

K

A

T

\*

E



**ORION**

## LA VETRINA COMPATTA

Molto di più di una semplice vetrina gelato.  
Linee semplici, spazi contenuti e visibilità ottimale.

## THE COMPACT SHOWCASE

Much more than an ice cream cabinet.  
Plain lines, reduced spaces, ideal visibility.

K A  
T \*  
E







Pannello frontale e fianco terminale RAL 9005.  
9005 RAL version for lateral and frontal panels.



Pannello frontale e fianco terminale RAL 4004.  
4004 RAL version for lateral and frontal panels.







Pannello frontale e fianco terminale RAL 9003.  
9003 RAL version for lateral and frontal panels.







## KATE

BT BASSA TEMPERATURA  
BT LOW TEMPERATURE

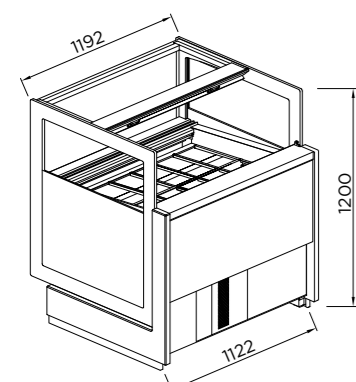
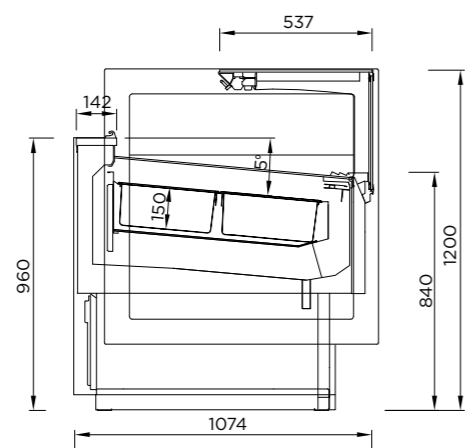

G6

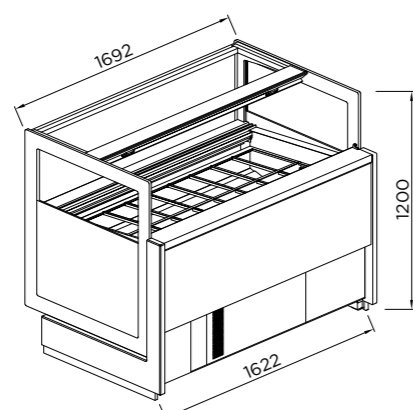

G9

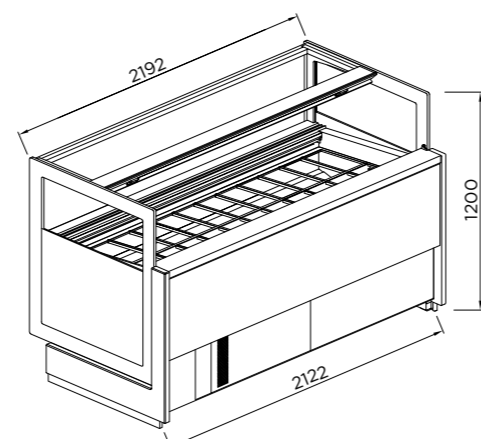

G12

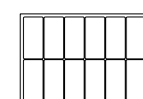

N°12 360x165 mm

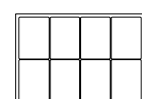

N°8 360x250 mm

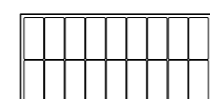

N°18 360x165 mm

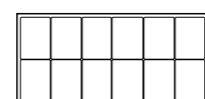

N°12 360x250 mm



N°24 360x165 mm

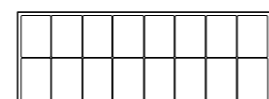

N°16 360x250 mm

	TEMPERATURA DI ESERCIZIO WORKING TEMPERATURE	RESA COOLING CAP.	ALIMENTAZIONE ELETTRICA ELECTRIC SUPPLY	POTENZA ASSORBITA MAX POWER INPUT	PESO NETTO NET WEIGHT
G6	-18/-20 °C	1550W	400V/50Hz	1300W	230 KG
G9	-18/-20 °C	1750W	400V/50Hz	1500W	340 KG
G12	-18/-20 °C	2160W	400V/50Hz	1800W	450 KG

### STRUTTURA:

- Basamento in tubolare
- Vetro frontale monolitico riscaldato apribile verso il basso
- Spalle in vetro camera
- Colori serigrafie fianco terminale in vetro camera: cornice perimetrale RAL 9006, porzione centrale RAL 7016
- Plafoniera di illuminazione a LED sul tettino
- Chiusura posteriore con tendine o scorrevoli

### STRUCTURE:

- Tubular structure
- Tempered heated frontal glass openable downwards
- End side heated glasses.
- Silk-screen printing color end side panel: outside frame RAL 9006, internal part RAL 7016
- LED lighting on top
- Rear closure with rolled curtain or sliding doors

### TECNOLOGIA:

- Quadro comandi del tipo elettronico con termostato e termometro digitale
- Sbrinatorio automatico programmabile
- Unità refrigerante interna con condensazione ad aria (optional ad acqua) compressore semi ermetico 380/3/50Hz. Su richiesta compressore ermetico 220/1/50Hz

### TECHNOLOGY:

- Electronic control board with digital thermometer and digital thermostat.
- Programmable electronic defrosting
- Internal air refrigerating unit (water-cooled as optional) semi-hermetic compressor 380/3/50Hz. On request hermetic compressor 220/1/50Hz

### OPTIONAL:

- Finitura del pannello di rivestimento frontale personalizzabile con RAL a scelta
- Canalizzazione

### OPTION:

- Finishing customisation RAL
- Canalization

## KATE

T+ TEMPERATURA POSITIVA  
T+ POSITIVE TEMPERATURE

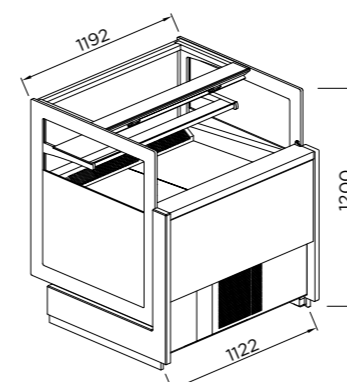
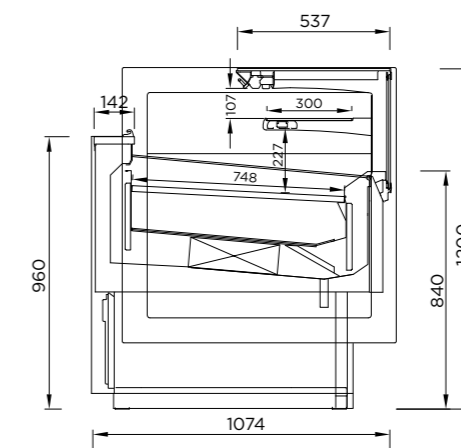

2M

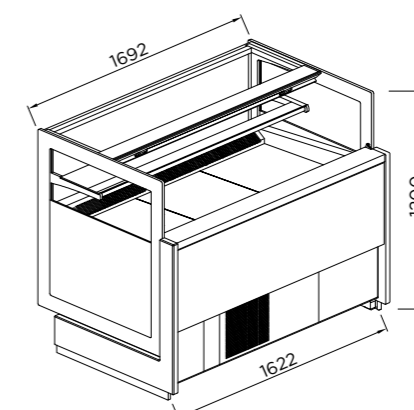

3M

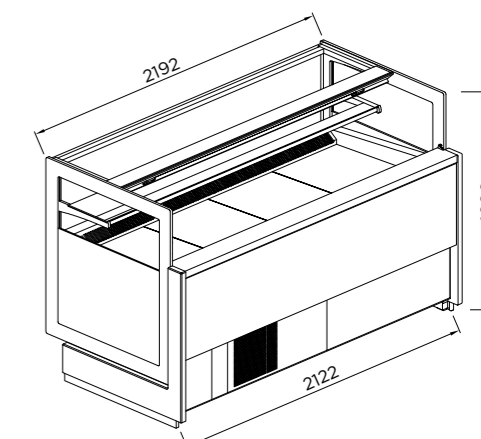

4M

	TEMPERATURA DI ESERCIZIO WORKING TEMPERATURE	RESA COOLING CAP.	ALIMENTAZIONE ELETTRICA ELECTRIC SUPPLY	POTENZA ASSORBITA MAX POWER INPUT	PESO NETTO NET WEIGHT
T+2M	+4/+6°C	748W	230V/50Hz	900W	210 KG
T+3M	+4/+6°C	1289W	230V/50Hz	1000W	290 KG
T+4M	+4/+6°C	1625W	230V/50Hz	1200W	350 KG

### STRUTTURA:

- Basamento in tubolare
- Vetro frontale monolitico riscaldato apribile verso il basso
- Spalle in vetro camera
- Colori serigrafie fianco terminale in vetro camera: cornice perimetrale RAL 9006, porzione centrale RAL 7016
- Plafoniera di illuminazione a LED sul tettino
- Chiusura posteriore con tendine o scorrevoli

### STRUCTURE:

- Tubular structure
- Tempered heated frontal glass openable downwards
- End side heated glasses.
- Silk-screen printing color end side panel: outside frame RAL 9006, internal part RAL 7016
- LED lighting on top
- Rear closure with rolled curtain or sliding doors

### TECNOLOGIA:

- Quadro comandi del tipo elettronico con termostato e termometro digitale
- Sbrinatorio automatico programmabile
- Unità refrigerante interna con condensazione ad aria (optional acqua) compressore ermetico 220/1/50Hz

### TECHNOLOGY:

- Electronic control board with digital thermometer and digital thermostat.
- Programmable electronic defrosting
- Internal air refrigerating unit (water-cooled as optional) hermetic compressor 220/1/50Hz

### OPTIONAL:

- Finitura del pannello di rivestimento frontale personalizzabile con RAL a scelta
- Canalizzazione

### OPTION:

- Finishing customisation RAL
- Canalization

EDIZIONE GENNAIO 2019

Hanno collaborato  
alla realizzazione  
di questo catalogo:

**Art Direction**  
ROSSANA TRUCCHIA

**Concept / Graphic Design**  
VDESIGN

**Photography Credits**  
STUDIO UAOH

**Print**  
GRAPHO 5 SERVICE

**ORION**

ORION  
VIALE DELL'INDUSTRIA 15  
60035 JESI (AN)  
ITALY  
PHONE: +39 0731 61531  
FAX: +39 0731 6153413  
INFOWEB@ORIONSTYLE.COM  
WWW.ORIONSTYLE.COM



VIALE DELL'INDUSTRIA, 15  
60035 JESI (AN) ITALY

T +39 0731 61 53 1  
F +39 0731 61 53 211

[WWW.ORIONSTYLE.COM](http://WWW.ORIONSTYLE.COM)  
[INFOWEB@ORIONSTYLE.COM](mailto:INFOWEB@ORIONSTYLE.COM)